

Live demonstration: A FSK-OOK Ultra Wideband Impulse Radio System with Spontaneous Clock and Data Recovery

Wei Tang¹, Shoushun Chen², Eugenio Culurciello^{1,3}

¹ Electrical Engineering Department, Yale University, New Haven, CT USA

² School of Electrical and Electronics Engineering, Nanyang Technological University, Singapore

³ Biomedical Engineering Department, Purdue University, West Lafayette, IN USA

wei.tang@yale.edu, eechenss@ntu.edu.sg, euge@purdue.edu

Abstract—We present a non-coherent wireless communication testing platform for ultra wide-band impulse radio (UWB-IR) with frequency-shift-keying (FSK) on-off-keying (OOK). Both transmitter and receiver platform will be present with a control graphic user interface (GUI) supported by Spartan-3 FPGAs. The transmitter chip is integrated while the receiver is build from off-the-shelf components. Monopole antennas are used in the system. The demonstration shows a transformative wireless communication technology for low power low cost short range applications.

I. INTRODUCTION

There is a growing needs for low power short range wireless communication systems for wireless sensor and biomedical applications. Non coherent UWB-IR system has the potential to satisfy the requirements for its low complexity design and implementation. One of the most challenging problem for the non-coherent UWB-IR system is to perform clock and data recovery with low power and low complexity circuits. In our design, we use the combination of the frequency shift keying and on off keying (FSK-OOK) [1] to achieve spontaneous clock and data recovery. The data rate can be varied during transmission. The maximum transmitter data rate can achieve 25Mbps. The system speed is limited by multi-path and interferences.

II. DEMONSTRATION DESCRIPTION

The UWB pulse-radio transmission system block diagram and photographs of the demo setup is shown in Fig. 1. The equipment will include two laptops, a UWB transmitter board and a receiver board. An oscilloscope (TDS-2014B) may be used to monitor waveforms at different nodes of the system.

The demo system is supported by Opal Kelly 3001v2 FPGA board. The file from the transmitter is send to the buffer in the FPGA, where the header will be added. The binary data is serialized via a 16 bit shift register and transmitted through the transmitter chip. The received RF signal is detected by the RF detector and digitized by comparators. When the header is matched, the binary stream will be send to the receiver buffer then to the computer via USB cable.

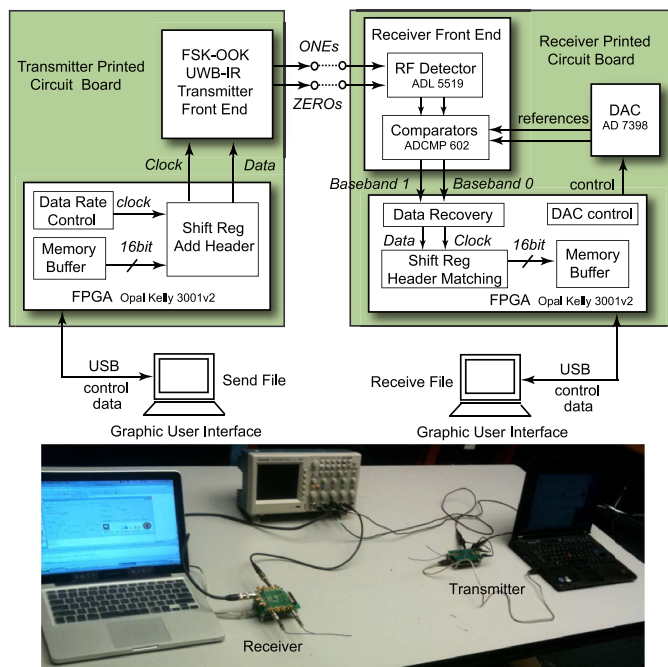

Fig. 1. System building block diagram and demonstration setup.

III. DEMONSTRATION EXPERIENCING

In this live demonstration, a visitor can choose a file (either text, image or video) at the transmitter computer, then send it to the receiver using the UWB impulse radio system. Graphic User Interface are developed for visitor to control the data transmission. The data rate can be controlled by the visitor from the GUI at the transmitter.

IV. TRACK SELECTION

This demo would be related to ISCAS 2012 track 3.3: UWB systems.

REFERENCES

- [1] W. Tang and E. Culurciello, "A non-coherent fsk-ook uwb impulse radio transmitter for clock-less synchronization," in *Circuits and Systems (ISCAS), 2011 IEEE International Symposium on*, may 2011, pp. 1295–1298.

A FSK-OOK Ultra Wideband Impulse Radio System with Spontaneous Clock and Data Recovery

Wei Tang¹, Shoushun Chen², Eugenio Culurciello^{1,3}

¹ Electrical Engineering Department, Yale University, New Haven, CT USA

² School of Electrical and Electronics Engineering, Nanyang Technological University, Singapore

³ Biomedical Engineering Department, Purdue University, West Lafayette, IN USA

wei.tang@yale.edu, eechenss@ntu.edu.sg, euge@purdue.edu

Abstract—In this paper, we present a demonstration system of a non-coherent Ultra Wideband (UWB) wireless impulse radio. The goal of this design is to meet the requirements in the short-range wireless data communication applications with low-power and low-complexity. The radio system exploits the UWB permission from IEEE 802.15.4a standard, and utilize the combination of frequency-shift-keying and on-off-keying as modulation and demodulation methods. The wireless system is able to achieve real-time wireless data transmission without complex construction of the data package. Furthermore, the system can perform asynchronous wireless communication or automatic clock and data recovery without synchronization process. The integrated transmitter was fabricated using TSMC 0.35 μ m CMOS process, with power consumption of 30 mW under 3.3 V supply. The integrated non-coherent transmitter can send data with 30 Mbps. The demonstration system includes a transmitter, a receiver and a graphic user interface.

I. INTRODUCTION

Recent applications are expecting high-speed low-power radio technologies for short-range wireless communication systems, such as personal area networks, body area networks and wireless implant bio-sensors [1]. In most of those systems, power is provided by battery or power-limited radio power supplies, so energy efficiency is the priority consideration when choosing wireless technologies. The second consideration is the data rate under the power budget, especially when a large scale sensor array is deployed, such as in wireless image sensors [2] and neural recording systems, in which a 10Mbps data rate with 10mW power cost is required [3]. So the general challenge is to find a wireless technology with low power and appropriate data rate.

The basic purpose of the short range wireless system is to replace a digital cable [4]. However, current high speed wireless technologies are often associated with complex coherent modulation and demodulation scheme, such as WiFi, MB-OFDM UWB and coherent UWB impulse radio systems. The power cost of those coherent systems are all above 50mW. In such systems, it requires high linearity devices and active local oscillators running at the receiver side, even when there is no active action at transmitter. Moreover, synchronization streams must be added into the preamble of the data package in order to help the receiver to perform clock and data recovery. Those methods increase the system power and complexity, and decrease the effective data rate. In this paper, we explored a non-coherent UWB wireless transmission modulation, in order

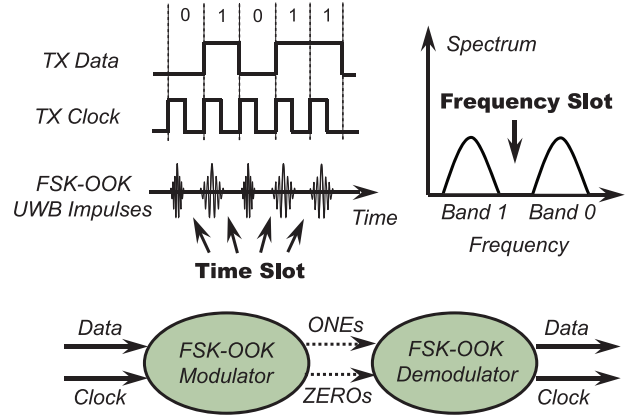

Fig. 1. Waveform and spectrum of the FSK-OOK UWB Impulse Radio. Both time slot and frequency slot are used to identify the polarity and number of the bits. The system converts the Data and Clock into ONEs and ZEROs for wireless transmission in order to save power when the data is sparse.

to improve the energy efficiency in the non-coherent wireless systems.

In order to minimize the power consumption, the active circuit in the radio should be shut down as much as possible. In other words, both transmitter and receiver should keep silent when there is no data to transmit. In such case, the non-coherent UWB impulse radio becomes an ideal candidate for short-range wireless solutions. The bottle-neck for high data rate non-coherent UWB system is the clock and data recovery. In order to perform clock synchronization, phase locked loop (PLL) or fast ADCs with baseband processors [5] are often used in non-coherent wireless systems, which requires active local clock and incessant processing. Another method is using Manchester Encoder/Decoder [2]. However, manchester decoder still needs receiver reference clock from the preamble of the data package [6]. Those methods are not feasible in a receiver with limited power budget. Also, the synchronization process becomes more challenging when the transmitter clock has large jitter.

The above problems can be solved by taking the advantage of the UWB impulse radio standard by IEEE 802.15.4a group. In this work, we demonstrate an asynchronous wireless communication prototype. The baseband signal is modulated by both frequency shift keying (FSK) and on-off-keying

(OOK), which means different symbols are separated by both frequency and time slot, as shown in Figure 1. Frequency slot is used to identify binary bits, while the time slot is used to distinguish the number of consecutive bits with the same polarity. FSK-OOK modulation only transmits data (ONEs and ZEROs) instead of transmitting both data and clock information. Thus, the system power is remarkably reduced when the data is sparse. When the RF signal is received, the receiver is able to identify the data simultaneously without clock synchronization. The advantage of this modulation method is that by doing so, any local oscillator can be removed from the receiver, and no wake-up time is required in the receiver when the transmission started. Also the synchronization stream is not necessary in the preamble of the data package, which can improve the effective data rate of the system. Moreover, because the receiver detects the incoming data without the help from the transmitter clock, the system can tolerate very large jitter of the transmitter clock. It means that during wireless transmission, the data rate can be varied in a wide range without changing the settings of the receiver. The drawback of this modulation method is that the two bands occupy wider frequency resource than traditional modulations. This modulation method trades the large bandwidth of UWB systems for data rate, power and system complexity. By optimizing the test-bed of our previous work [7], a demonstration system is implemented to evaluate the wireless communication performance.

II. SYSTEM AND CIRCUIT DESIGN

Figure 2 presents the architecture of the FSK-OOK UWB transmission system. The modulation and demodulation process is explained in [7]. In order to save power, the *TX Clock* is enabled only when the transmitter is sending data. ONEs and ZEROs are separated in the transmitter baseband. The transmitter baseband generates the baseband pulses in return zero (RZ) format, which is then up-converted by the RF pulse generator and buffered by the RF power amplifier for transmitting. The system can also work in an asynchronous mode. In asynchronous wireless communication, the *Transmitter Baseband* can be removed. The *TX BB "1"* and *TX BB "0"* signals are replaced by *Asyn Positive* and *Asyn Negative* signals, respectively. The transmitter is a fully digital circuit. When there is not data to be sent, the transmitter is silent and the power is only cost by leakage current.

The non-coherent receiver detects the incoming ONEs and ZEROs using the high pass filter (HPF) and the low pass filter (LPF) with following RF Envelop Detectors and Level-crossing Comparators. The receiver doesn't have any local oscillator. The *RX Data* is recovered with a D-flip flop with an asynchronous reset. Rising edges of the ONEs and ZEROs reconstructs the *RX Data* waveform, while the *RX Clock* is recovered using an OR gate. The final *RX Data* is then sampled by the falling edge of the *RX Clock* to fully recover the information.

The simplified schematic of the integrated transmitter is shown in Figure 3. The baseband signals are created by

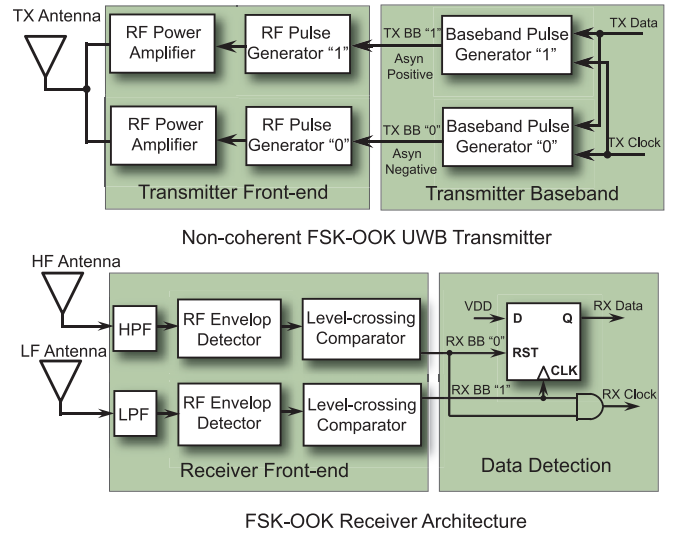

Fig. 2. Block Diagram of Non-coherent FSK-OOK UWB Transmitter and Receiver. Bit "1"s and "0"s are transmitted in different frequency band. In asynchronous mode, the *TX BB "1"* and *TX BB "0"* signals are replaced by "Asyn Positive" and "Asyn Negative" signals. The data is detected directly by a D flip-flop and an OR gate.

combining the *TX Clock* and *TX Data* with AND gates. The following VCOs are built by inverter rings instead of LC VCOs in most of the RF transmitters. That is because in non-coherent impulse radio systems, accuracy of the carrier frequency is not required. Also the Ring VCOs are power efficient with short shut-down and wave-up time. The HF VCO and LF VCO have 3 stages and 11 stages of the inverter ring, which results in the central frequency at 1.1GHz and 330MHz, respectively. The carrier frequency of ONEs and ZEROs are widely separated, which is different from the traditional FSK. According to the spectrum of the On-Off-Keying modulation, the width of the carriers in the spectrum of FSK-OOK should be twice of the maximum data rate of the system to avoid interference.

III. EXPERIMENTAL RESULTS

The integrated transmitter is fabricated in TSMC 0.35 μm CMOS process with active area of 0.03 mm². The chip is mounted on a FR-4 PCB connected to an Opal Kelly 3001 FPGA board with 3.3V power supply as shown in Figure 4. In our implementation, the receiver is build by off-the-

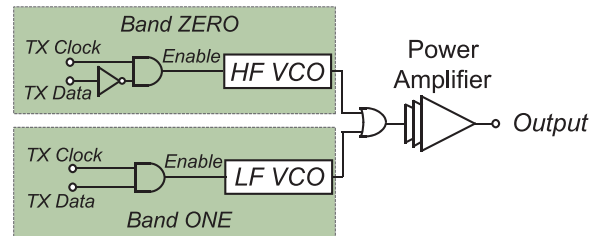

Fig. 3. Simplified Schematic of the integrated FSK-OOK transmitter. *TX Data* and *TX Clock* are combined with the AND gates to create RZ code as the baseband, which controls the *Enable* of the VCO. The combined RF pulses are buffered with an inverter chain as the *Power Amplifier*.

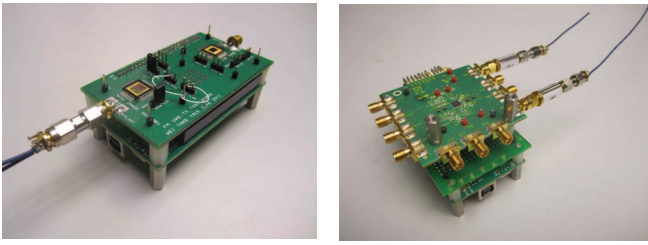

Fig. 4. Transmitter (left) and Receiver (right) setup. Opal Kelly XEM3001FPGA board are used to support the transmitter and receiver. The receiver is build with off-the-shelf components.

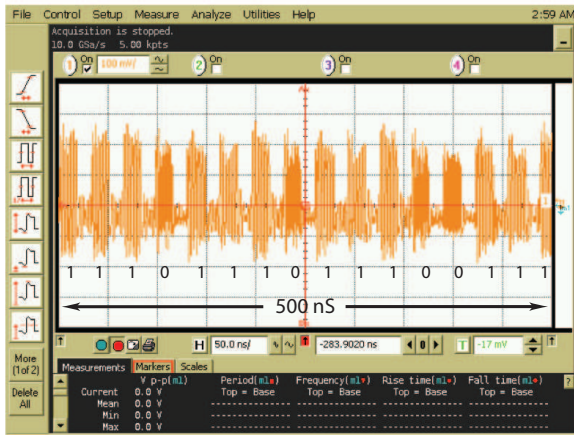

Fig. 5. Measured FSK-OOK modulation RF waveform. The "1"s and "0"s are up-converted to 330MHz and 1.1GHz separately. Time slots are inserted between consecutive symbols.

shelf components. Another Opal Kelly 3001 FPGA board is supporting the receiver system by providing reference voltage to the comparator via a 12-bit DAC AD7398. Channel "1" and "0" are separated with the low pass filter (LPF) and high pass filter (HPF), which are VLF630 and VHF880 coaxial filters from Mini-Circuits. The RF energy detectors and Level-crossing comparators are the ADL5519 and ADCMP602 from Analog Device Inc. Quarter wave length monopole antennas are used for detecting band "1" and "0" signal separately at the receiver. The transmitter is connected to two parallel monopole antennas.

Figure 5 shows the measured waveform of the transmitter with 30 Mbps data rate. Figure 6 presents its frequency spectrum from 9 kHz to 1.8 GHz. The central frequency of the band "0" is located in 330MHz while the carrier of band "1" is at 1100MHz. This spectrum doesn't meet the FCC mask for UWB impulse radio system: the band "1" is located in the forbidden band of the FCC mask. This is simply because of the fabrication process limitation. When more advanced technology is available, the band "1" frequency should be located above 2GHz then the FCC requirement can be satisfied.

Figure 7 shows the measured transmitter baseband and receiver front-end waveform from the digitizer after RF detector with a 30 Mbps data rate. A low-pass filter and a high-

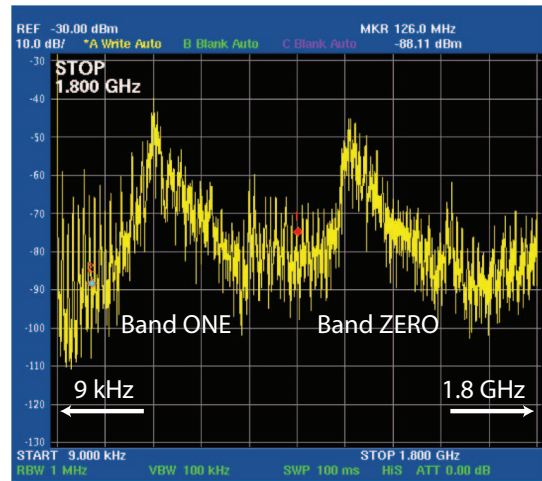

Fig. 6. Measured FSK-OOK modulation spectrum with resolution bandwidth of 1MHz. Band "1" and Band "0" are located at 330MHz and 1100MHz separately.

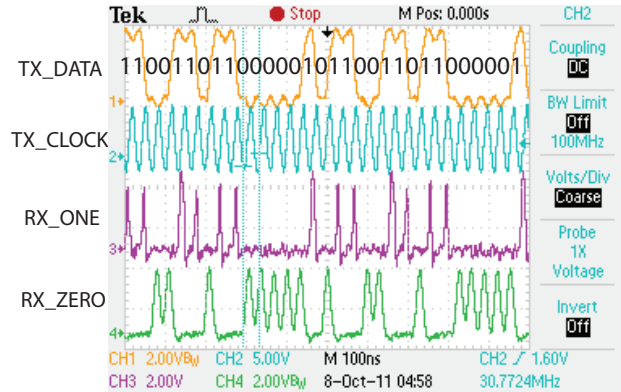

Fig. 7. Measured FSK-OOK demodulation output at 30 Mbps data rate. From top to bottom: Transmitter DATA, Transmitter CLOCK, Received ONEs, Received Zeros. Baseband ONEs and ZEROS are identified separately after the low pass filter and high pass filter. After level cross sampling, clock and data recovery can be achieved with simple digital circuits spontaneously.

pass filter separates the ONES and ZEROS signals. A two-channel RF log detector is then used to detect RF burst at both bands. The output of the RF detector is digitized by level crossing sampling circuits. The received data and clock is finally recovered with the D-flipflop and the OR gate. In this measurement, the distance between the RX and TX is 20 cm. While the RF front end can transmit and receive with 30 Mbps, the system communication data rate is limited by the response time and sensitivity of the RF detectors and comparators. Both the RF detector and comparator in the system have the rising time and falling time of 8 to 10 ns, which limits the maximum data rate to 25 Mbps. The data rate of the wireless link is also limited by multi path, environment noise and interference.

This setup system is a proof of concept of the FSK-OOK modulation and demodulation for non-coherent UWB impulse radio. It doesn't meet the requirements of FCC which asks a 500MHz bandwidth usage of the impulse radio system. This

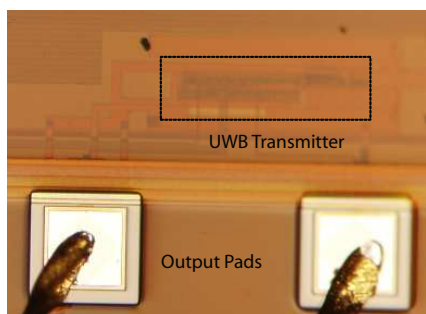

Fig. 8. Micrograph of the Fabricated Transmitter Chip.

problem can be solved by frequency hopping (FH) or time hopping (TH) in the transmitter. In this non-coherent system, the TX carrier of the band "1" and "0" can be switched to any frequency below the cut-off frequency of the LPF, and beyond the cut-off frequency of the HPF, respectively. The switching of frequency during communication will not affect the receiver as well as the RF detector is board-band. Also, if the time hopping method is used, the system can be treated as an asynchronous wireless communication system. As the receiver does not need the clock information from the transmitter for decoding, the time hopping from the transmitter also will not affect the data recovery process during transmission. In other words, the receiver doesn't need to know the hopping pattern of both FH and TH in this non-coherent wireless system.

In this simple implementation, only the LPF and HPF are used to reject noise. Interference rejection technologies such as notch filters, as well as channel codings for error detection, can be applied in future designs. Compared to our perviously published FSK-OOK system [7], this implementation is a simplified designed for an wireless image sensor system. The radio part is more compact and only occupies 100um by 300um silicon area. The robustness of the signal is improved by the monopole antenna.

IV. SUMMARY

We designed and tested the non-coherent FSK-OOK UWB impulse radio wireless communication system for spontaneously clock and data recovery without synchronization. The chip micrograph is illustrated in Fig. 8. The chip active area is 0.03 mm^2 . Table I summarizes the main properties of the chip. The test result shows that the transmitter circuit consumes 30 mW and the transmitter data rate is able to achieve 30 Mbps. Compared to other non-coherent UWB impulse radio systems, this design achieved higher data rate due to the simple data recovery circuit. A comparison of the recent non-coherent UWB impulse radio system is summarized in Table II. This design is a competitive solution for the short range wireless communications.

V. ACKNOWLEDGEMENTS

We thank Dr. Peter Kindlmann and Dr. Fred Sigworth for discussion. This project is partially funded by NSF DBI-0649349, ONR N00014-08-1-1014 and ONR N00014-08-1-

Process technology	0.35 μm CMOS
Chip size (um)	300 x 100
Modulation	Non-coherent FSK-OOK
Supply voltage	3.3V
Frequency range of band "0"	1.1 GHz
Frequency range of band "1"	330 MHz
Maximum TX data rate	30 Mbps
RX Local Clock or PLL	No
Synchronization time	0
Maximum TX power	30 mW

TABLE I
SUMMARY OF THE CHIP CHARACTERISTICS.

References	This work	[8]	[9]	[10]
Process	0.35 μm	90 nm	90nm	90nm
Modulation	FSK-OOK	OOK	OOK	S-OOK
TX data rate	30 Mbps	16 Mbps	5 Mbps	1 Mbps
Synchronizer Method	D flip-flop OR gate	Baseband Processor	Duty Cycling PLL	Ring LO Digital logic

TABLE II
COMPARISON WITH RECENT REFERENCES.

0065, NIH R01 NS06511. The support of TSMC in chip fabrication is gratefully acknowledged.

REFERENCES

- [1] M. Chae, W. Liu, Z. Yang, T. Chen, J. Kim, M. Sivaprakasam, and M. Yuce, "A 128-channel 6mw wireless neural recording ic with on-the-fly spike sorting and uwb transmitter," in *IEEE International Solid-State Circuits Conference, 2008. ISSCC 2008. Digest of Technical Papers.*, feb. 2008, pp. 146 –603.
- [2] S. Chen, W. Tang, and E. Culurciello, "A 64x64 pixels uwb wireless temporal-difference digital image sensor," in *Circuits and Systems (ISCAS), Proceedings of 2010 IEEE International Symposium on*, 30 2010-june 2 2010, pp. 1404 –1407.
- [3] R. R. Harrison, P. T. Watkins, R. J. Kier, R. O. Lovejoy, D. J. Black, B. Greger, and F. Solzbacher, "A low-power integrated circuit for a wireless 100-electrode neural recording system," *IEEE Journal of Solid-State Circuits*, pp. 123 – 133, January 2007.
- [4] D. M. Bobkin, *RF Engineering for Wireless Networks: Hardware, Antennas and Propagation*. Elsevier, 2005.
- [5] P. Mercier, M. Bhardwaj, D. Daly, and A. Chandrakasan, "A 0.55v 16mb/s 1.6mw non-coherent ir-uwb digital baseband with 1ns synchronization accuracy," in *IEEE International Solid-State Circuits Conference - Digest of Technical Papers, 2009. ISSCC 2009.*, Feb. 2009, pp. 252–253,253a.
- [6] Xilinx, *Manchester Encoder-Decoder for Xilinx CPLDs*, 1st ed., Xilinx, Oct 2002.
- [7] W. Tang and E. Culurciello, "A non-coherent fsk-ook uwb impulse radio transmitter for clock-less synchronization," in *Circuits and Systems (ISCAS), 2011 IEEE International Symposium on*, may 2011, pp. 1295 –1298.
- [8] D. C. Daly, P. P. Mercier, M. Bhardwaj, A. L. Stone, Z. N. Aldworth, T. L. Daniel, J. Voldman, J. G. Hildebrand, and A. P. Chandrakasan, "A pulsed uwb receiver soc for insect motion control," *Solid-State Circuits, IEEE Journal of*, vol. 45, no. 1, pp. 153–166, Jan. 2010.
- [9] X. Wang, R. Dokania, Y. Zhuang, W. Godoycki, C. Dorta-Quinones, M. Lyons, and A. Apsel, "A self-synchronized, crystal-less, 86 uw, dual-band impulse radio for ad-hoc wireless networks," in *Radio Frequency Integrated Circuits Symposium (RFIC), 2011 IEEE*, june 2011, pp. 1 –4.
- [10] M. Crepaldi, C. Li, K. Dronson, J. Fernandes, and P. Kinget, "An ultra-low-power interference-robust ir-uwb transceiver chipset using self-synchronizing ook modulation," in *IEEE International Solid-State Circuits Conference Digest of Technical Papers (ISSCC), 2010*, feb. 2010, pp. 226 –227.