

Parasitic-compensated quadrature LC oscillator

C.C. Boon, M.A. Do, K.S. Yeo, J.G. Ma and R.Y. Zhao

Abstract: The paper presents a method for improving the phase noise performance of a CMOS quadrature LC oscillator through parasitic compensation. Owing to the parasitic resistance in the inductor, the LC oscillator suffers from a low Q -value, which degrades its phase noise performance. In this design, through the parasitic-compensation method, the LC oscillator will be made to oscillate at the frequency when the effective impedance of the parallel LC resonator is at the peak. This will increase the Q -value of the LC resonator, which improves the phase noise performance of the circuit. A 2.63 GHz quadrature CMOS LC oscillator with a phase noise of -112.3 dBc/Hz at 600 kHz offset is demonstrated, consuming 7.5 mW of power using an on-chip spiral inductor model.

1 Introduction

LC voltage-controlled oscillators (VCO) commonly used as local oscillators are a bottleneck in the design of a fully integrated radio frequency (RF) circuit. Compared to other topologies, such as inverter-based ring oscillators, LC oscillators are preferred because of their high quality factor (Q). However, the Q -value of an integrated inductor is poor in CMOS technology due to the high substrate loss. The thermal noise generated due to the substrate loss causes significant phase noise [1].

To produce quadrature outputs, some recent designs [2, 3] couple two differential VCOs. However, this technique doubles both the area and the power consumption of the oscillator without significant gain in terms of phase noise. The design in this paper aims to use the coupling technique to improve the phase noise performance while producing quadrature outputs.

This paper starts with a brief analysis of the effect of a lossy inductor on the resonant characteristics of a parallel LC resonator. Then the parasitic-compensated circuit topology, which is based on the coupling structure [2, 3], will be introduced. This will be followed by the analysis and measured results of a parasitic-compensated LC oscillator.

2 Effect of a lossy inductor on phase noise

To show the effect of a lossy inductor on phase noise, we have to describe the characteristics of an LC tank. The discussions will be restricted to a parallel LC resonator used in the design. Figure 1 shows a typical parallel LC resonator. The effective impedance of a parallel resonator (Z_p) is

$$\begin{aligned} |Z_p| &= \left| 1 / \left(\frac{CR}{L} + j \left(\omega L - \frac{1}{\omega C} \right) \right) \right| \\ &= 1 / \sqrt{\left(\frac{CR}{L} \right)^2 + \left(\omega L - \frac{1}{\omega C} \right)^2} \end{aligned} \quad (1)$$

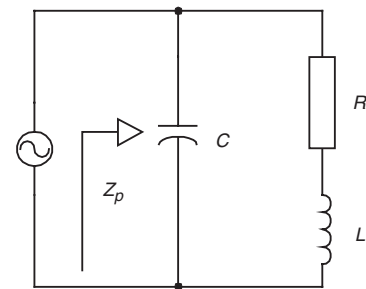

Fig. 1 Parallel LC resonator

From the above equation, the maximum impedance value of the parallel resonator would be $|Z_{pmax}| = L/(RC)$ at the resonant frequency ω_p , where $\omega_p = 1/(LC)^{1/2}$, for $\omega L \gg R$. Figure 2 shows the corresponding resonant characteristics. The quality factor, which is defined as the sharpness of the impedance magnitude against frequency characteristic, can be expressed as follows:

$$Q_{pmax} = \frac{|Z_{pmax}|}{\omega_p L} \quad (2)$$

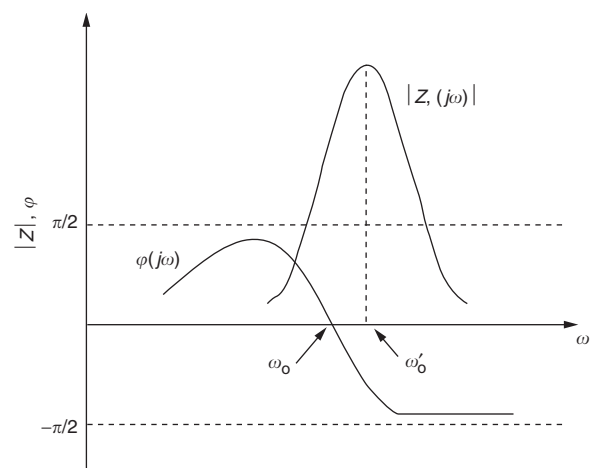

Fig. 2 Resonant characteristic of a parallel LC resonator

However, due to the parasitic effects, the resonator does not oscillate at the frequency when $|Z_p| = |Z_{pmax}|$. This consequently lowers the Q -value, and causes degradation in the phase noise performance. The resonant impedance and

the resonant frequency in the above discussions are derived under the assumption that the series resistance of the inductance is much smaller than its conductance ($\omega L \gg R$). However, the Q -value of the CMOS integrated inductor is very low, so the above condition cannot be satisfied. If the series resistance of the inductor is included, the impedance of the parallel LC tank becomes

$$Z = \frac{(R + jL\omega) \frac{1}{jC\omega}}{R + jL\omega + \frac{1}{jC\omega}} = \frac{L}{CR} \frac{1 - j\frac{R}{\omega L}}{1 + j(\frac{\omega L}{R} - \frac{1}{\omega CR})} \quad (3)$$

To start and maintain a stable oscillation, the oscillator is required to satisfy the Barkhausen criteria, where the total loop gain must be larger than unity and the total phase shift of the oscillator loop must be equal to 360° . This implies that, at the resonant frequency, the phase of (3) is equal to zero, resulting in

$$-\frac{R}{\omega_o L} = \frac{\omega_o L}{R} - \frac{1}{\omega_o CR} \quad (4)$$

This will lead us to the resonant frequency of a lossy parallel LC tank, ω_o :

$$\omega_o = \sqrt{\frac{1}{LC} - \frac{R^2}{L^2}} \quad (5)$$

Equation (5) shows that the resonant frequency is lower than the ideal lossless case where $\omega_o = 1/(LC)^{1/2}$. Furthermore, the oscillator is no longer oscillating at the frequency where the impedance magnitude is at the maximum. The magnitude of the impedance in (3) is:

$$|Z| = \left| \frac{(R + jL\omega) \frac{1}{jC\omega}}{R + jL\omega + \frac{1}{jC\omega}} \right| = \left| \frac{R + jL\omega}{1 - \omega^2 LC + jRC\omega} \right| \quad (6)$$

$$|Z| = \sqrt{\frac{R^2 + \omega^2 L^2}{(1 - \omega^2 LC)^2 + (RC\omega)^2}} \quad (7)$$

The maximum value of $|Z|$ is obtained by differentiating (7):

$$\frac{d|Z|}{d\omega} = \frac{1}{2} \left(\frac{R^2 + \omega^2 L^2}{(1 - \omega^2 LC)^2 + (\omega RC)^2} \right)^{-1/2} \frac{d}{d\omega} \left(\frac{R^2 + \omega^2 L^2}{(1 - \omega^2 LC)^2 + (\omega RC)^2} \right) \quad (8)$$

When $d|Z|/d\omega = 0$, the solution for (8) will give us the frequency at which the impedance of the lossy parallel LC tank is maximum:

$$\omega'_o = \frac{1}{\sqrt{LC}} \sqrt{\sqrt{1 + \frac{2CR^2}{L}} - \frac{CR^2}{L}} \quad (9)$$

The impedance magnitude, shown in Fig. 2, peaks at a frequency (ω'_o) higher than the resonant frequency (ω_o). Hence, the magnitude of the resonator impedance at the resonant frequency is lower than its maximum value. Thus, we can expect a lower Q -value, which leads to a degradation of phase noise.

3 Parasitic-compensated LC oscillator topology

The parasitic-compensated LC oscillator is based on the coupling structure [2, 3], to increase the tuning range [3] and

to generate quadrature output [2]. However, using the coupling structure to increase the tuning range suffers from drawback of the degradation of phase noise as the resonant frequency is shifted further away from the frequency where the impedance of an LC tank is at maximum.

Figure 3 shows the block diagram of the coupled VCO [3]. G_1 and G_2 are two identical fixed frequency oscillators. Their outputs are coupled to their inputs with the coupling coefficients M_1 and M_2 . Both oscillators will synchronise to a single oscillation frequency ω at steady state. The output of each oscillator must satisfy the following equations:

$$(X + M_2 Y) G_1(j\omega) = X \quad (10)$$

$$(Y + M_1 X) G_2(j\omega) = Y \quad (11)$$

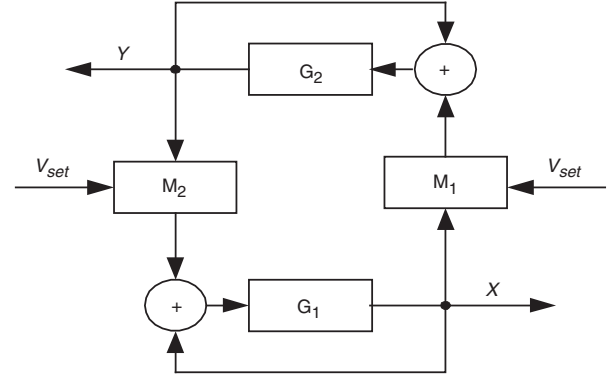

Fig. 3 Block diagram of coupled VCO

where M_1 and M_2 are scalars, and X and Y are the output phasors for oscillator 1 and 2, respectively. Since the oscillators are identical, $G_1 = G_2 = G$ and $M_1 = -M_2 = M$ can be satisfied. Hence, from (10) and (11) we can show that $X^2 + Y^2 = 0$ and therefore $X = \pm jY$. Thus, quadrature outputs X and Y are generated [3]. The new oscillation frequency ω can be found by substituting $X = \pm jY$ into (10) or (11):

$$(1 \pm jM)G(j\omega) = 1 \quad (12)$$

where $G(j\omega) = Z(j\omega)G_m$, and $\phi(Z(j\omega)) = \pm \tan^{-1} M$ are the possible conditions for the oscillation.

The above analysis shows that by selecting a suitable coupling coefficient M , the resonant frequency can be shifted to the frequency ω'_o , where the magnitude of the impedance is at the maximum. V_{set} is used to control the value of M .

4 Analysis of a 2.63 GHz parasitic-compensated quadrature LC oscillator

Figure 4 shows the parasitic-compensated LC oscillator. Table 1 shows the parameters of the oscillator design. L_{tank} and C_{tank} are the tank inductance and tank capacitance, respectively, of the LC oscillator. From Fig. 4:

$$M_1 = \frac{g_{P2}}{g_{N0} + g_{P0}} \quad G_1(j\omega) = (g_{N0} + g_{P0})Z_0(j\omega) \quad (13)$$

$$M_2 = \frac{g_{P3}}{g_{N1} + g_{P1}} \quad G_2(j\omega) = (g_{N1} + g_{P1})Z_1(j\omega) \quad (14)$$

where g_{P0} , g_{P1} , g_{P2} , g_{P3} , g_{N0} and g_{N1} are the transconductances of transistors P_0 , P_1 , P_2 , P_3 , N_0 and N_1 , respectively. From the parameters given in Table 1, and by solving (5), the resonant frequency of a lossy parallel LC tank ω_o is obtained to be 2.59 GHz. With a proper selection of M

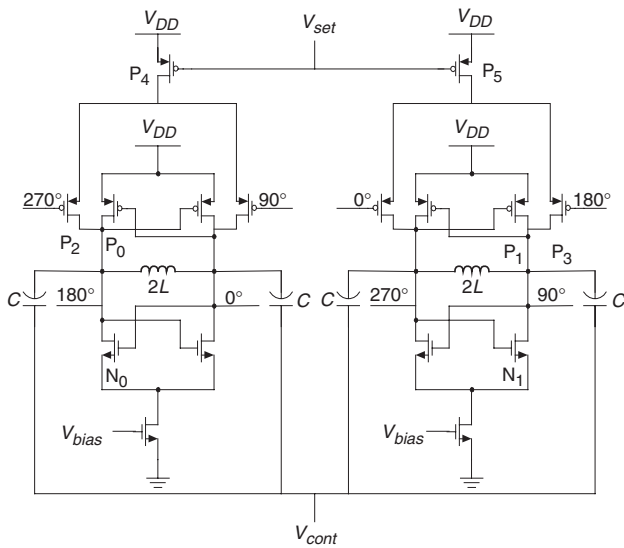

Fig. 4 Parasitic-compensated LC oscillator

Table 1: Parameters of oscillator design

Tank inductance L_{tank}	1.84 nH
Tank capacitance, C_{tank}	2.02 pF
Series resistance of inductor	4.30 Ω

using (13) and (14), the oscillation frequency can be shifted to $\omega_o' = 2.63$ GHz, as given by (9), where the maximum impedance is obtained.

Using the circuit simulator SpectreRF, the simulated phase noise at the frequency of ω_o' is -112.8 dBc/Hz at 600 kHz offset. The figure was compared with the phase noise of the same design but coupled without to parasitic-compensated circuit. The phase noise simulations show an improvement of 4.0 dB when a parasitic-compensated circuit is implemented.

5 Experimental results

The oscillator in Fig. 4 was designed and fabricated using the CSM's (Chartered Semiconductor Manufacturing) $0.18\ \mu\text{m}$ CMOS process. The active chip area is $1200\ \mu\text{m} \times 1500\ \mu\text{m}$ and the VCO core power consumption is 7.5 mW for a supply voltage of 1.5 V. Figure 5 shows a microphotograph of the quadrature LC oscillator. The

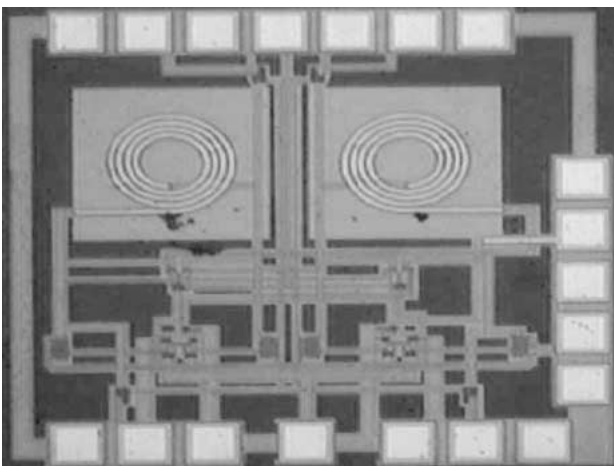

Fig. 5 Microphotograph of quadrature LC oscillator

quality factors of the spiral inductor and MOS varactor used in the design are 8.5 and 40, respectively.

Figure 6 shows the oscillator phase noise performance at 600 kHz offset against the control voltage V_{set} , and the results are summarised in Table 2. The phase noise performance of the oscillator at ω_o' (2.63 GHz) is improved by 4.1 dB compared to that at ω_o (2.59 GHz), which agrees with the simulation results. For another resonant frequency taken arbitrarily at $\omega_o'' = 2.65$ GHz, the phase noise performance degrades by 3.3 dB as compared to that at ω_o' . The three resonant frequencies are achieved by tuning the control voltage V_{set} to 0 V, 1 V and 1.5 V, which corresponds to frequencies of ω_o , ω_o' and ω_o'' , respectively. The measured results show that the phase noise performance is improved when the resonant frequency is shifted from ω_o to ω_o' , where a higher Q -value is obtained. The results also show that the phase noise performance degrades when the oscillator oscillates at ω_o'' , which is further away from the frequency of the peak impedance magnitude. Figure 7 shows the phase noise performance of the oscillator over the tuning range of 2.59 GHz to 3.13 GHz. The power spectrum of the oscillator at ω_o' is shown in Fig. 8.

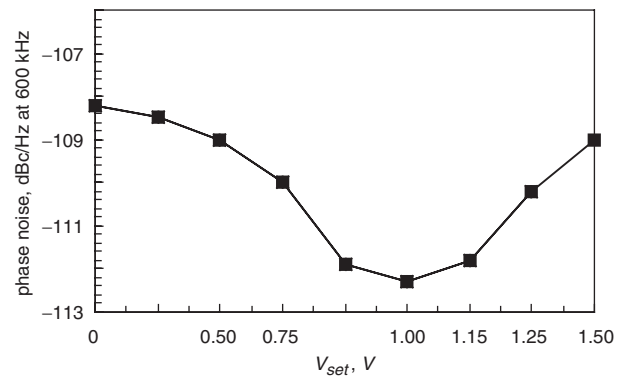

Fig. 6 Phase noise performance against V_{set}

Table 2: Measured results of oscillator

V_{set} V	Resonant frequency, GHz	Phase noise at 600 kHz offset, dBc/Hz
0.0	2.59	-108.2
1.0	2.63	-112.3
1.5	2.65	-109.0

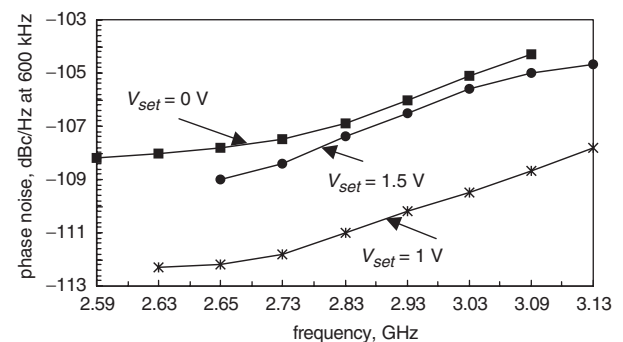

Fig. 7 Phase noise performance over tuning range of 2.59 GHz to 3.13 GHz

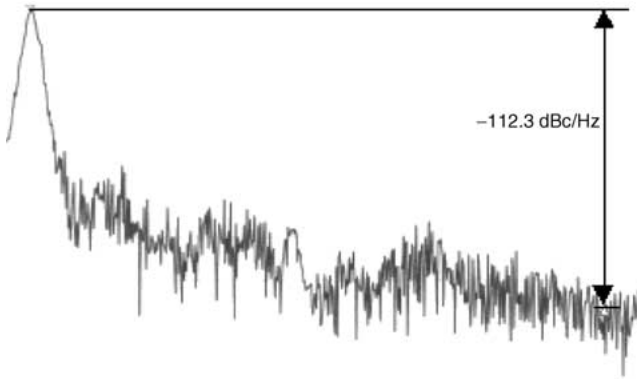

Fig. 8 Power spectrum of oscillator at ω_o'

Table 3: Performance comparison of this work with state-of-the-art quadrature oscillators

Ref.	f_o , GHz	Δf , Hz	Phase noise, dBc/Hz	Power, mW	FOM, dB
[2]	0.90	100k	-85.0	30.0	-164.0
[3]	6.29	1M	-98.4	18.0	-161.0
[4]	1.00	600k	-126.0	13.0	-179.3
[5]	2.60	5M	-110.0	26.0	-168.5
[6]	1.93	600k	-122.2	27.6	-177.9
[7]	1.80	3M	-130.0	6.0	-177.8
[8]	1.80	3M	-132.0	66.0	-171.1
[9]	5.22	2M	-113.0	21.2	-168.0
[10]	1.57	600k	-133.5	30.0	-187.0
[11]	1.80	3M	-143.0	20.0	-185.5
This paper	2.63	600k	-112.3	7.5	-176.4

6 Conclusions

In this paper, we have shown that the coupled VCO can compensate for the degradation of phase noise performance, which is due to the parasitic effect of the low- Q inductor. A 2.63 GHz fully integrated LC quadrature oscillator with parasitic-compensated circuit was implemented as an example. The measured phase noise

was -112.3 dBc/Hz at 600 kHz offsets from the 2.63 GHz carriers. The designed oscillator consumes only 7.5 mW from a 1.5 V supply voltage.

In Table 3, the commonly adopted expression for the figure of merit (FOM) [11] is used to compare the performance of some recently published oscillators with this oscillator:

$$FoM = 10 \log \left[\left\{ \frac{f_o}{\Delta f} \right\}^2 \frac{1}{L(\Delta f)P} \right] \quad (15)$$

where f_o is the oscillation frequency, Δf is the offset frequency, $L(\Delta f)$ is the phase noise at Δf , and P is the power consumption in milliwatts. From Table 3, it can be seen that the performance of the novel oscillator is comparable with other state-of-the-art oscillators in terms of FOM.

7 References

- Ham, D., and Hajimiri, A.: 'Concepts and methods in optimization of integrated LC VCOs', *IEEE J. Solid-State Circuits*, 2001, **36**, (6), pp. 896-909
- Rofougarn, A.: 'A 900 MHz CMOS LC oscillator with quadrature outputs'. IEEE ISSCC Digest of Technical Papers, February 1996, pp. 392-393
- Liu, T.-P.: 'A 6.5 GHz monolithic CMOS voltage-controlled oscillator'. IEEE ISSCC Digest of Technical Papers, February 1999, pp. 404-405
- Kim, J.J., and Kim, B.: 'A low-phase noise CMOS LC oscillator with a ring structure'. IEEE ISSCC Digest of Technical Papers, February 2000, pp. 430-431
- Lam, C., and Razavi, B.: 'A 2.6/5.2-GHz CMOS voltage-controlled oscillator'. IEEE ISSCC Digest of Technical Papers, February 1999, pp. 402-403
- ElSayed, A.M., and Elmasry, M.I.: 'Low-phase-noise LC quadrature VCO using coupled tank resonators in a ring structure', *IEEE J. Solid-State Circuits*, 2001, **36**, (4), pp. 701-705
- Craninckx, J., and Steyaert, M.: 'A 1.8-GHz low-phase-noise CMOS VCO using optimized hollow spiral inductors', *IEEE J. Solid-State Circuits*, 1997, **32**, pp. 736-744
- Hung, C.M., and Kenneth, K.O.: 'A packaged 1.1-GHz CMOS VCO with phase noise of -126 dBc/Hz at a 600-kHz Offset', *IEEE J. Solid-State Circuits*, 2000, **35**, (1), pp. 100-103
- van der Tang, J., van de Ven, P., Kasperkovitz, D., and van Roermund, A.: 'Analysis and design of an optimally coupled 5-GHz quadrature LC oscillator', *IEEE J. Solid-State Circuits*, 2002, **37**, (5), pp. 657-661
- Vancorenland, P., and Steyaert, M.S.J.: 'A 1.57-GHz fully integrated very low-phase-noise quadrature VCO', *IEEE J. Solid-State Circuits*, 2002, **37**, (5), pp. 653-656
- Tiebout, M.: 'Low power low-phase-noise differentially tuned quadrature VCO design in standard CMOS', *IEEE J. Solid-State Circuits*, 2001, **36**, (7), pp. 1018-1024