

A Hybrid of Plot-based and Character-based Interactive Storytelling

Yundong Cai, Chunyan Miao, Ah-Hwee Tan, and Zhiqi Shen

School of Computer Engineering,
Nanyang Technological University, Singapore
{CAIY0004, ascymiao, asahtan, ZQshen}@ntu.edu.sg

Abstract. Interactive storytelling in the virtual environment attracts a lot of research interests in recent years. *Story plot* and *character* are two most important elements of a story. Based on these two elements, currently there are two research directions: plot-based and character-based interactive storytelling. However, plot-based approach lacks the refinement of character behaviors as character-based approach. On the other side, character-based approach does not follow a well organized story plot so that the moral of the story might be distorted. Therefore, there is a need to develop an integrated framework to achieve the balance between conveying story moral and enhancing the modeling of character behaviors. In this paper, we propose a hybrid system of the plot-based and character-based approaches. It is constructed as a multi-agent system (MAS), which involves a scriptwriter agent, a director agent, virtual actor agents and other support agents. Fuzzy Cognitive Goal Net (FCGN) is used by the scriptwriter agent to generate story plot, which includes various meaningful storylines. The director agent selects the storyline dynamically and dispatches the scenes to the virtual character agents as behaviors through the decomposing algorithms. With the system, dynamic storylines and character behaviors are generated in realtime based on the audience interactions and context changes. The audiences are able to experience different levels of interactions as an observer, a character or a director. A case study prototype called “Mystery Illness Investigation at Nanyang Town” has been implemented based on the proposed system.

Key words: simulation, interactive storytelling, story authoring

1 Introduction

Storytelling is widely used in everyday human communication, through which people share information and convey messages. Chris Crawford defines the term *interactive storytelling* as, a form of interactive entertainment in which a player adopts the role of protagonist in a dramatically rich environment[4]. As interactive storytelling is a mixture of conventional storytelling and user interactions, it provides the audiences the capability to interact with the storyteller or the characters, so that dynamic and nonlinear storylines can be achieved. Interactive storytelling in the virtual environment has become hot area in today’s interactive storytelling research.

In traditional form of storytelling, a storyteller would present the scenario of a story to the audiences in a predefined way (also known as a *plot*), which limits the variation in character interactions and context. At the same time, the audiences prefer to experience different or personalized story scenario through requirements or feedbacks using interactions, but such dynamic interactions might distort the intension of the story.

Due to the tradeoff between story narrative and user interactions, striking a balance between the two is a big challenge.

Currently, there are a lot of work focused on either interactive story authoring/generation or behaviors of virtual characters. Different kinds of storytelling engines are created for story authoring and generation [6, 9]. Moreover, Marc Cavazza et al.[1–3] proposed an character-based interactive storytelling engine, in which the behavior of each character is modeled with hierarchical task network. The characters are able to interact with each other through performing tasks with constraints of pre-conditions. Some commercial products, like Façade[7], are also implemented.

However, to our knowledge, there is a lack of research efforts at combining the design of story plot and character behaviors. Plot-based methods are good at interactive story generation, but fail to model the dynamic behaviors of virtual characters. Though it ensures to enlighten the moral of a story at the high level, there is a lack of interactions among the characters and the audiences as well as personalization of the characters. On the other hand, character-based approach focuses on designing the specific behaviors of virtual characters. It ensures that subtle interactions can be handled by the character. However, the most important element of the story, i.e. the intension might be twisted. This paper proposes a hybrid system that combines plot-based story authoring and character-based behavior modeling. The hybrid system includes the story author in the form of a *scriptwriter agent*, the story executor as a *director agent*, the story performers as *virtual actor agents* and other supporting agents. The *scriptwriter agent* drafts the nonlinear plot with rational alternatives according to the story scenario. The *director agent* verifies the plot by the *scriptwriter agent* and selects the scenes of story dynamically based on the user interactions or context, and dispatches the tasks to the actors involved in the scenes. Each *virtual actor agent* performs the tasks assigned by the *director agent*, interacts with each other and the audience. To model the story plot as well as the character behavior, an agent modeling tool, Fuzzy Cognitive Goal Net (FCGN) is employed, in which the temporal causal relationships of the scenes and behaviors as well as the reasoning of the context and user interactions are clearly defined. Through the hybrid system, the audiences are able to experience storytelling through various levels of interactions.

The paper is organized as follows. Section 2 talks about the structure of our proposed hybrid system of the interactive storytelling, and explains the process of interactive storytelling. In Section 3 we illustrate how an agent modeling tool Fuzzy Cognitive Goal Net can be used by the scriptwriter agent and the director agent for the story authoring and task dispatch to virtual actors. Then in Section 4, we show a case study implemented based on our interactive storytelling system in the virtual environment, and evaluate the system through comparisons. Lastly, we conclude the paper and present our future plans.

2 A hybrid approach for interactive storytelling system

In order to bridge the gap between the plot-based approach and character-based approach for interactive storytelling, a hybrid system is proposed, by which the interactive storytelling system is constructed as a multi-agent system (MAS). The interactive storytelling process is carried out through the goal execution of the agents, which will be illustrated in details in this section.

2.1 Structure of Interactive Storytelling System

Agents are goal-oriented, autonomous objects, which work in specific context. The goal of a storyteller is to convey a story to audiences with certain interactions from the audiences. Interactive storytelling in the virtual environment involves agents with multiple roles, i.e. scriptwriter, director and virtual characters. The structure of the multi-agent system is depicted in Figure 1.

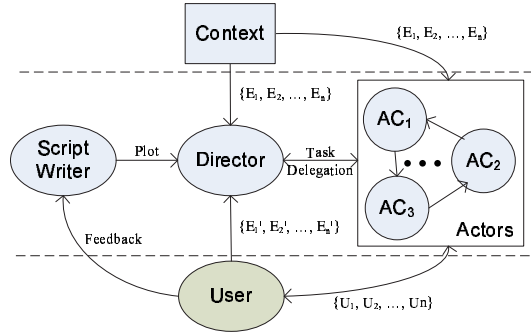

Fig. 1. Multi-agent System View for Interactive Storytelling Hybrid System

Agents The circles in Figure 1 show the agents involved in the interactive storytelling system.

Scriptwriter A scriptwriter agent constructs the plot of the story. Different from the traditional story plot, the plot created by the scriptwriter agent is nonlinear, which provides choices and alternatives for audiences.

Director It is also known as drama manager by some researchers. A director agent is the storyteller, who is responsible for selecting and determining the storyline from the whole plot given by the scriptwriter agent. According to the user interactions U as well as context changes E , a reasonable storyline is provided by the director dynamically.

Virtual Actors/Characters The virtual actors are the virtual entities to perform the scenes of the story, which are shown in a box container named as “Actors” in the Figure 1. AC_1, AC_2, AC_3 are three sample actors. They take over the tasks as behaviors from the director and perform in the temporal sequence. Among the actors, the one which is keen to convey the moral of the story is called protagonist. The actors interact with each other according to the plot, and the audience interactions U and context changes E may affect the behaviors of the actors also.

Audience/User An audience/user is the person who joins in the virtual environment to experience the storytelling with interactions. The audience can have its virtual representative in the virtual environment or be invisible to other actors. The user is able to join the storytelling as one of the actors.

In interactive storytelling, the audience is able to interact with the virtual characters, the director and the context. As shown in Figure 1, U_1, U_2, \dots, U_n are the interaction with the virtual characters, E'_1, E'_2, \dots, E'_n is the interactions with the director. Also, the audience can send feedback to the scriptwriter for commenting new storylines.

Story Context Story context represents the circumstances that a story scene occurs. Every story has its specific context, with which the story scenes are meaningful. Context awareness is an important property of a robust interactive storytelling system, so that the director agent and character agents are able to generate the storyline or perform the scenes dynamically and believably with the context criteria. For interactive storytelling in virtual environment, the context includes:

- Virtual environment, e.g. position of virtual actors, availability of virtual objects.
- Audience preference, e.g. emotion, personality.
- System and resources

Conventional storytelling starts with the introduction of the story context, often using "Once upon a time". The context is static and straightforward. However, the context in interactive storytelling is dynamic, which increases the complexity of the storytelling system. In the hybrid system, contexts are modeled to communicate with the director and actors with events E .

2.2 Interactive Storytelling Process

The process of interactive storytelling is the process of pursuing goals for the agents, an sample of which is shown in Figure 2. It includes four steps: story authoring, story executing, scene dispatching and character performing.

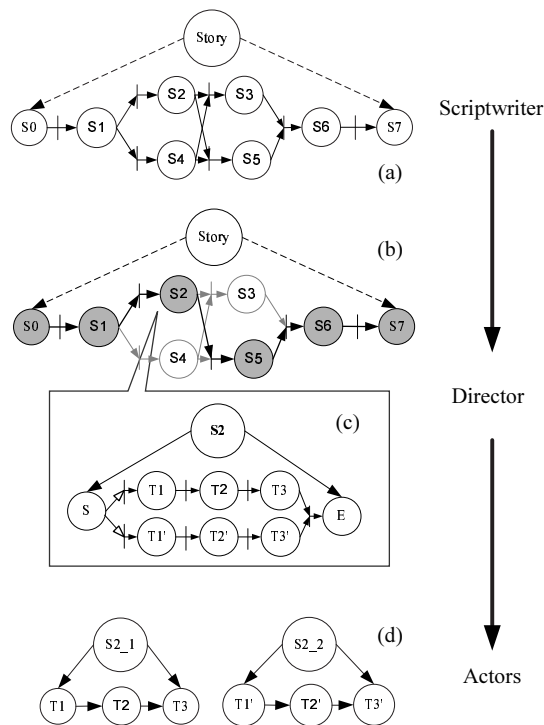

Fig. 2. Interactive Storytelling Process: Agents vs. Goals. (a) The scriptwriter agent designs story plot with various choices; (b) The director agent selects story scenes dynamically; (c) The story scene S_2 involves performance between two actors; (d) The director agents dispatches scene to two actors as their behaviors.

Story Authoring The scriptwriter creates the story plot which contains multiple storylines. Figure 2(a) shows a sample story scenario, which contains seven possible scenes from S_0 to S_7 . The story scenario contains four alternative storylines as:

$$S_0 \Rightarrow S_1 \Rightarrow S_2 \Rightarrow S_3 \Rightarrow S_6 \Rightarrow S_7 \quad (1)$$

$$S_0 \Rightarrow S_1 \Rightarrow S_2 \Rightarrow S_5 \Rightarrow S_6 \Rightarrow S_7 \quad (2)$$

$$S_0 \Rightarrow S_1 \Rightarrow S_4 \Rightarrow S_3 \Rightarrow S_6 \Rightarrow S_7 \quad (3)$$

$$S_0 \Rightarrow S_1 \Rightarrow S_4 \Rightarrow S_5 \Rightarrow S_6 \Rightarrow S_7 \quad (4)$$

After the plot construction, the scriptwriter agent sends the whole story plot to director agent for execution.

Story Executing/Selection Though the interactive storytelling is non-linear, the director agent selects only one storyline based on the user interactions or context variables dynamically. Scene selection is done through fuzzy cognitive reasoning mechanism, which will be explained in details in next section. As shown in Figure 2(b), path 2 is selected as the storyline, in which scenes S_2 and S_5 are selected and scenes S_4 and S_3 are not selected.

Scene Dispatching Each scene of the plot might involve different actors and different tasks, so that the director agent distributes the scene to relevant actors dynamically. In the example, scene S_2 involves communication between two actors as shown in Figure 2(c), which contains two concurrent tasks belonging to two actors respectively. Therefore, the director agent separates the scene to two sub-scenes, assigns sub-scene $S_{2.1}$ and sub-scene $S_{2.2}$ to two actors respectively. The story plot modeling and task dispatch process are described in details in the next section.

Character Performing After the actors receive tasks from the director agent, they will perform the tasks as behaviors in the sequence of temporal relationship. The composite task/behavior can be further decomposed to atomic tasks/behaviors. It is shown that, plot-based approach focuses more on the first two steps, i.e. story authoring and story selection. On the other side, character-based focuses more on the last two steps, i.e. scene dispatch and actor performing, and the scene dispatch is done by the human, but not automatically and dynamically. In the hybrid system, user-awareness and context-awareness of the storytelling are achieved by the director agent and virtual actor agents through fuzzy cognitive reasoning mechanism.

3 Fuzzy Cognitive Goal Net (FCGN)

An efficient model is required to achieve the autonomy of story generation and story performing. In our hybrid system, Fuzzy Cognitive Goal Net (FCGN) is used by the scriptwriter and the director to generate and select story plot. Through the task dispatch mechanism, the director arranges the behaviors for the actors involved in story scenes dynamically.

3.1 Story Elements Definitions

In order to model the interactive storytelling process, there is a need to define the key elements of storytelling semantically at the first step.

Definition of Scene A scene, also known as an event, is an atom of a story plot, which involves the interactions among a number of virtual actors with dedicated roles, under certain context. It can be expressed as a tuple

$$S = [AC_1, AC_2, \dots, AC_n, T_1, T_2, \dots, T_n, C]$$

Here, AC_1 to AC_n are the actors involved in the scene, T_1 to T_n are the tasks/behaviors assigned to each actor respectively, C is the context of the scene.

Definition of Actor An actor is the virtual entity which performs the tasks assigned from the director. It is a hybrid of goal-driven and reactive agent. Each actor has its own profile, which includes states and preference. It is expressed as

$$AC = [S_t, P, T]$$

where S_t is a list of states, P is a list of preferences and T is the behaviors of the actor, which is empty initially and assigned by the director agent in realtime.

Definition of Task A task of a actor is an acting slice assigned by the director. It is also called *behavior* from the perspective of the actor. A composite task can be decomposed to a sequence of sub tasks recursively. A task is expressed as

$$T = [T_1, T_2, \dots, T_n]$$

where the task T is composed of tasks T_1, T_2, \dots, T_n .

Definition of Context Context is the circumstances in which an event occurs. It is represented as a C , which records a list of states of virtual environment.

3.2 Model Description

In order to model the temporal structure of the story plot and the user interactions, Fuzzy Cognitive Goal Net (FCGN), is used for interactive story authoring and character behavior modeling. The model is made up of two parts: plot planning tool based on Goal net and the context reasoning mechanism using Fuzzy Cognitive Maps (FCMs). Goal net is used as the story generation tool for the scriptwriter and director agents. Fuzzy Cognitive Maps empower the director ability to create dynamic path by reasoning about user interactions and environment context, and strengthen character's task selection in realtime.

A scene of story/drama is regarded as a goal to be executed by the director agent. The goals are loaded to the director agent according to the temporal relationships of the scenes. For a complex scene in the presentation path, the goal can be decomposed to more specific sub goals. Depending on the user interactions and context, different consequent goals may be reached after a certain goal, i.e, different scenes are achieved in different situations. Fuzzy Cognitive Maps are used for the decision making or goal selection by analyzing the relationships among related concepts. Goal Net is illustrated in details in the following parts separately in terms of their functionalities in the interactive storytelling model. Detailed descriptions of Fuzzy Cognitive Maps can be found at [5].

Structure of Goal Net Goal net is a tool for modeling multi-agent system proposed by Shen[10]. It has been successfully used in the multi-agent system modeling in business forecasting and E-learning[8]. Goal net model is composed of *Goals* and *transitions*. *Goals*, represented by circles, are used to represent the goals that an agent

needs to pursue in order to achieve final goal. *Transitions*, represented by arcs and vertical bars, connect from the input goal to the output goal, specifying the relationship between the two goals. Each transition is associated with a task list which defines the possible tasks that the agent needs to perform in order transit from the input goal to the output goal. A goal net example is shown in storytelling process (Figure 2).

There are two kinds of goals in Goal Net, *atomic goals* and *composite goals*. An *atomic goal* is a primitive state which cannot be further divided, while a *composite goal* can be split into goals connected via transitions. Therefore, a complex goal can be recursively decomposed into sub-goals and sub goal nets. The hierarchical structure simplifies the goal modeling process with different levels of abstraction.

In Goal Net, there are four types of temporal relations of goals represented by *transitions:sequence, choice, concurrency* and *synchronization*, which are shown in Figure 3. The transitions have the following meanings:

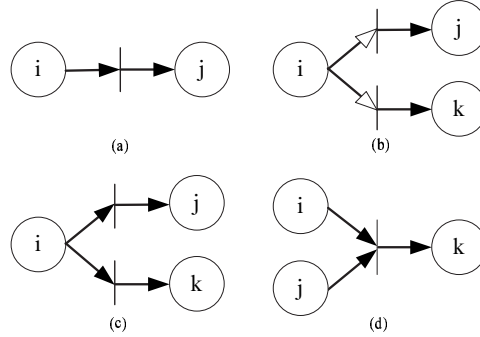

Fig. 3. Goal Net Transitions: (a) Sequence (b) Concurrency (c) Choice (d) Synchronization

Sequence: A direct sequential causal relationship between input goal i and output goal j

Choice: A selective connection from input goal i to possible output goals j and k , and only one output goal can be selected based on selection criteria

Concurrency: Input goal i at completing the tasks, all the output goals j and k can be achieved simultaneously

Synchronization: A synchronization point from different input goals i and j to a single output goal k , and the output goal can only be achieved when all its input goals are synchronized

In a Goal Net modeling, a goal is represented as S_i , and the transition is represented as T_i .

Plot Planning with Goal Net Goal Net is a very expressive and efficient tool to model the story plot for interactive storytelling.

The events are related in the temporal causal order in the storytelling. In the model, each scene/event S_i is represented as a goal, the causal relationship between scene S_i and S_{i+1} is represented with the transition T_i . The tasks for the agent to transit from scene S_i to S_{i+1} are represented as the task list at the transition T_i . A general storyline is encapsulated within each Goal Net. Moreover, multiple storylines are generated due to user interactions or context changes, the goal net shows different possible storylines

with the relation of 'Choice'. Therefore, the director has a combination of the ascension and climax to form the story in the process of storytelling. A complex scene is represented as a composite goal, and a simple scene is represented as an atomic goal. The composite goal can be further divided into atomic goals such that a complex scene is split into small scenes for story narrative. Theoretically, Goal Net is capable to model story scenarios with different levels of complexities.

The *transitions* of goal net are adequate and capable to describe different relationships between story scenes in interactive storytelling. The *sequence* transition is used when two scenes has temporal causal relationships. The *concurrency* transition is used when two scenes are independent, such that the presentation order by the drama manager is not important. The *choice* transition is the most important to the user interaction and context variables change, as it might lead to different scene after the current scene. The *synchronization* transition is needed for the concurrent scenes, such that the next scene can be achieved only after the concurrent scenes are achieved. Moreover, the combination of *transitions* allows to model complicated relationships among scenes, thus it is able to model a very complex storytelling.

The director agent is responsible for presenting the story scenes from the goal net according to causal relationships among the scenes.

Task Dispatching Goal Net is not only used as the story plot modeling tool, but also the modeling tool for the user behaviors. Task dispatching is an important step wherein the director agent assigns the tasks to different actors in a scene autonomously and dynamically. A typical algorithm is shown below.

```

Given: Scene S = [AC1, ... ACn, T, C]
For i = 1 to n do
    Ti = Find (S, T, ACi, C)
    ACi ← Ti
End

```

An example is shown in Figure 2(c) and 2(d). The scene is separated to subgoals according to the actors, effects of context to actors. Then the subgoals are assigned to the actors as their behaviors. Concurrency and synchronization transitions are used here to model the independence of the actors and their negotiations.

4 Case Study: “Mystery Illness Investigation at Nanyang Town”

4.1 Story Implementation

A story scenario, namely “Mystery Illness Investigation at Nanyang Town”, was implemented using the hybrid system. The story is to teach secondary students about illnesses in normal life. The stories show how investigators explore the virtual town and investigate the mystery illness. By talking to different people (avatars), or through conducting lab experiments, the investigators need to find the symptoms of the mystery illness, study the differences among diseases, and conclude the thorough review over the mystery illness at last. The investigators' results includes name of the disease, symptoms, precautions and so on. In the story, the investigators also can practice their knowledge about illness in the virtual world.

The scriptwriter agent models the story scenario as Figure 4. As shown in Figure 4,

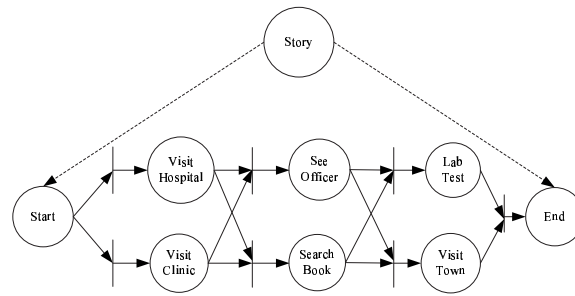

Fig. 4. Fuzzy Cognitive Goal Net for Illness Investigation Scenario by the Scriptwriter Agent

the investigator have many choices in the investigation. For example, he/she can go to either the hospital or the clinic to check the symptoms of the mystery illness and how widely the illness is spread. Depending on the availability of the officer in health ministry, the investigator can choose to ask for differences of different illnesses from the officer, or go to library to check them from the books. Moreover, he/she can go to the town to verify conclusion about the mystery illness, or he can do some further laboratory tests.

The director agent selects a storyline dynamically based on the user interactions and

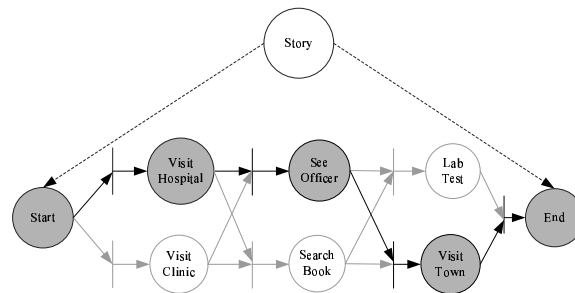

Fig. 5. Storyline Generated the Director Agent

current context. A selected storyline is as shown in Figure 5, in which the investigator visited the hospital for illness symptoms, then went to meet officer to query about the differences of the illnesses, lastly went to visit the town to confirm the conclusion. Different input states, like position of the investigation is near to the town and he/she is not much energetic, are used by the agent to make decisions. Figure 6 shows a detailed design of scene “visit the hospital”. The scene involves three actors: a doctor, a nurse and the investigator.

The visualization engine is ActiveWorlds 3-D virtual environment powered by Renderware. As shown in Figure 7, the director agent dispatches the tasks of visiting different places to the actors, and the audience is able to interact in the first-person view and third-person view.

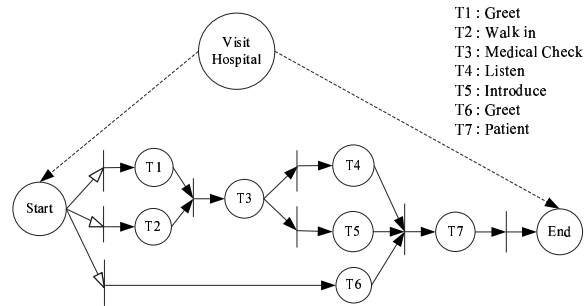

Fig. 6. "Visit Hospital Scene"

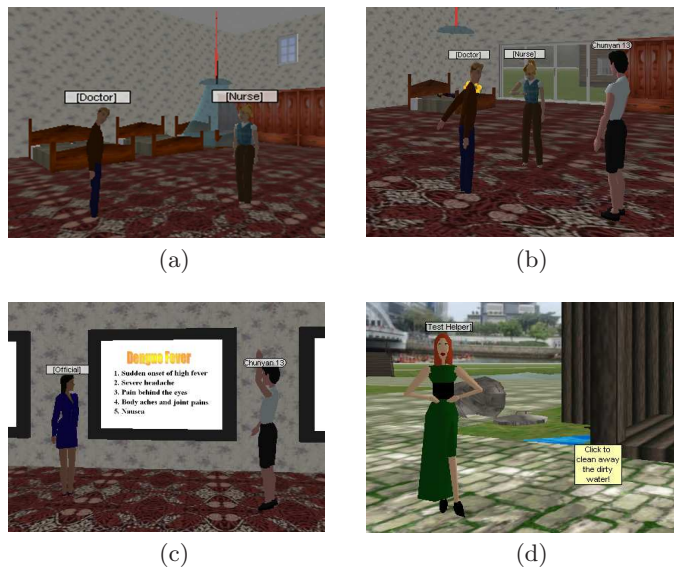

Fig. 7. Snapshots for (a) talking to the doctor and nurse as protagonist (b) watching the protagonist talking to doctor and nurse (c) visiting the officer in health ministry (d) applying knowledge in mystery house

4.2 Comparisons

The comparisons of the hybrid system with plot-based approach (PB) and character-based approach (CB) is shown in the Table 1.

Factors	PB	CB	Hybrid
Story Generation Autonomy	Yes	No	Yes
Character Performing Autonomy	No	Yes	Yes
Context Awareness	High Level	Low Level	High & Low Level

Table 1. Comparisons with Plot-based and Character-based Interactive Approached

4.3 User Interaction Evaluation

The ultimate goal for interactive storytelling is to enhance the experience of audiences through enabling interaction. Therefore, there is a need to discuss interaction capabilities within the hybrid system. The role of the audience/user in the storytelling determines the interactions it can make. In the proposed hybrid system, the audience/user is able to act in different roles, and interact at different levels, as shown in Table 2. Same as conventional storytelling and some of interactive storytelling systems,

Role of User	View	Level of Interactivity
Spectator/Observer	Third-Person View	Low-level (Indirect)
Director	Top View	High Level
Actor	First-Person View	Low-level (Direct)

Table 2. User Interaction Levels

the audience is a spectator/observer with the third-person view. As an observer, there is no task or behavior assigned by the director for participating in the storytelling. Therefore, he/she can watch the performance of the virtual actors, and only have limited interactions with the virtual environment. For example, he/she can change the position or availability of some objects required by the plot.

Moreover, according to the definition of the interactive storytelling, the audience is able to participate as a protagonist. The audience is able to interact with other virtual actors directly and contribute to the progress of the storytelling. The first-person view and the direct interaction increase the experience of immersion greatly.

Lastly, the system enables the audience to perform as a director or interact with the director as interactive story authoring systems, which selects the storyline dynamically based on audience preference or context changes, and assigns the tasks to actors for performing. The story authoring encourages the audience at high level design over the story scenario, including choosing the storyline, the characters and so on.

5 Conclusions

In this paper, we propose a hybrid system of plot-based and character-based interactive storytelling. The system is constructed based on a multi-agent architecture. Different from other research efforts, we involve story authoring as well as character behavior modeling together in the system. Through this combination, the user is able to make the interactions at the levels of authoring and storytelling. Fuzzy Cognitive Goal Net (FCGN) is used for the scriptwriter agent to create the nonlinear plot. The plot provides the director agent different choices according to user's dynamic interactions and context changes. Director agent dispatches the actions to the virtual actors as their goals, and the virtual actors act based on the assigned goal and interact with each other dynamically.

References

1. F. M. S. Cavazza, M. Charles. Character-based interactive storytelling. *Intelligent Systems, IEEE [see also IEEE Intelligent Systems and Their Applications]*, 17(4):17–24, 2002.
2. M. Cavazza, F. Charles, and S. J. Mead. Interacting with virtual characters in interactive storytelling. In *Proceedings of the first international joint conference on Autonomous agents and multiagent systems*, pages 318 – 325, Bologna, Italy, 2002.
3. S. C. M. Charles, F.; Mead. Character-driven story generation in interactive storytelling. In *Virtual Systems and Multimedia, 2001. Proceedings. Seventh International Conference on*, pages 609–615, Berkeley, CA, 2001.
4. C. Crawford. *Chris Crawford on Interactive Storytelling*. New Riders., Berkeley, CA, US, 2005.
5. J. A. Dickerson and B. Kosko. Virtual worlds as fuzzy cognitive maps. In B. Kosko, editor, *Fuzzy Engineering*. Prentice Hall, Englewood Cliffs, New Jersey, 1994.
6. B. Magerko and J. Laird. Building an interactive drama architecture. In *First International Conference on Technologies for Interactive Digital Storytelling and Entertainment*, pages 226–237, Darmstadt, Germany, 2003.
7. M. Mateas and A. Stern. Façade: An experiment in building a fully-realized interactive drama. In *Game Developers Conference, Game Design track*, San Jose, USA, 2003.
8. Z. Shen, C. Miao, X. Tao, and R. Gay. Goal oriented modeling for intelligent software agents. In *Proceedings of IEEE/WIC/ACM International Conference on Intelligent Agent Technology, 2004*, pages 540–543, 2004.
9. R. M. Young, M. O. Riedl, M. Branly, A. Jhala, R. J. Martin, and C. J. Saretto. An architecture for integrating plan-based behavior generation with interactive game environments. *Journal of Game Development*, (1):51–70, 2004.
10. S. Zhiqi. *GOAL-ORIENTED MODELING FOR INTELLIGENT AGENTS AND THEIR APPLICATIONS*. PhD thesis, Nanyang Technological University, 2003.